

Extron AgTECT Aeration Control

Product User's Guide



Minneapolis, MN US
Phone: (763) 544-4197
Fax: (763) 544-4419
extroncompany.com

sales@extroncompany.com

All Rights Reserved
©2019 Extron Company
Minneapolis, MN USA
Patent Pending

Contents

| | |
|--|----|
| Product User's Guide | 1 |
| 1.0 Description and Intended Use | 3 |
| 2.0 Scope and Audience | 5 |
| 3.0 Safety..... | 6 |
| 4.0 Features and Accessories | 7 |
| 5.0 Product Description | 7 |
| 6.0 Mechanical Specifications..... | 8 |
| 7.0 Electrical Specifications | 13 |
| 8.0 User Interface..... | 13 |
| 9.0 Technical Specifications..... | 14 |
| 10.0 Mechanical Installation..... | 14 |
| 11.0 Electrical Installation | 15 |
| 12.0 Operation and Use | 20 |
| 12.1 Commissioning..... | 20 |
| 12.2 Use..... | 20 |
| 13.0 FAQ and Troubleshooting..... | 23 |
| 14.0 Preventative Maintenance | 28 |
| 15.0 Spares, Repair and Replacement..... | 30 |
| 16.0 Ordering Information..... | 30 |
| 17.0 End of Life | 31 |
| 18.0 Regulatory Declaration and Agency Information | 32 |
| 19.0 Warranty..... | 32 |
| 20.0 Normative Document References | 33 |
| 21.0 Copyright..... | 33 |
| 22.0 Support Contact..... | 33 |

1.0 Description and Intended Use

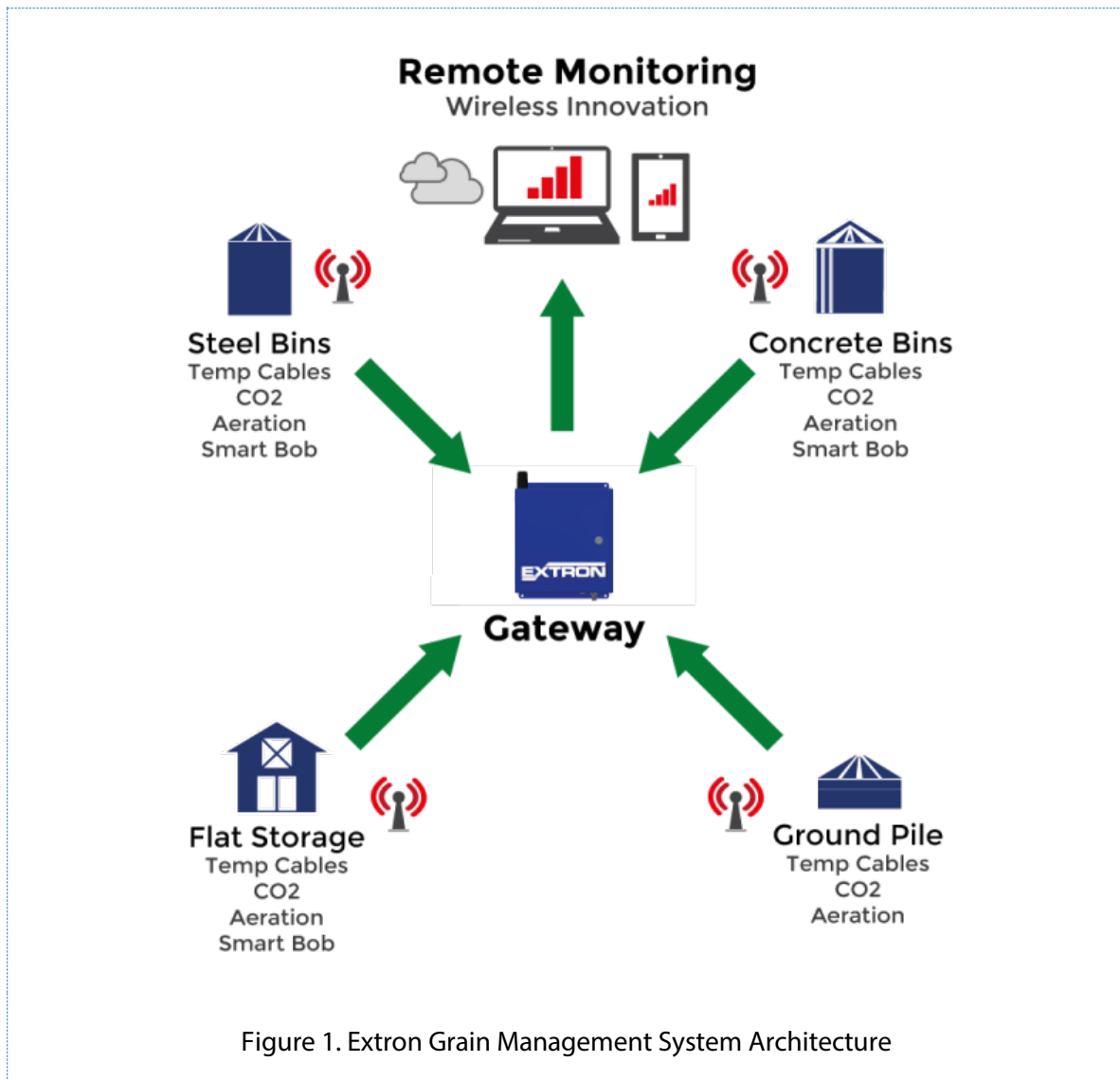

The Extron Aeration Control communicates wirelessly on-site with the Extron Gateway. The Extron Gateway includes a modem that communicates with servers over the cellular network so that the site may be configured and controlled through a web page.

The Extron Remote Management website provides the means to configure and to monitor the Extron Gateway and each Extron Aeration Controller to achieve that targeted system performance.

Each Extron Aeration Controller may be configured with an array of options to tailor it to a desired performance.

The Extron Aeration Control is a VFD-enabled device designed to provide optimized control and monitoring of a single fan used to condition and to protect stored grain. The VFD (Variable Frequency Drive), or Inverter, built in to the Extron Aeration Control provides the means by which the fan's speed is adjusted and monitored. User-defined parameters can be set to optimize fan usage.

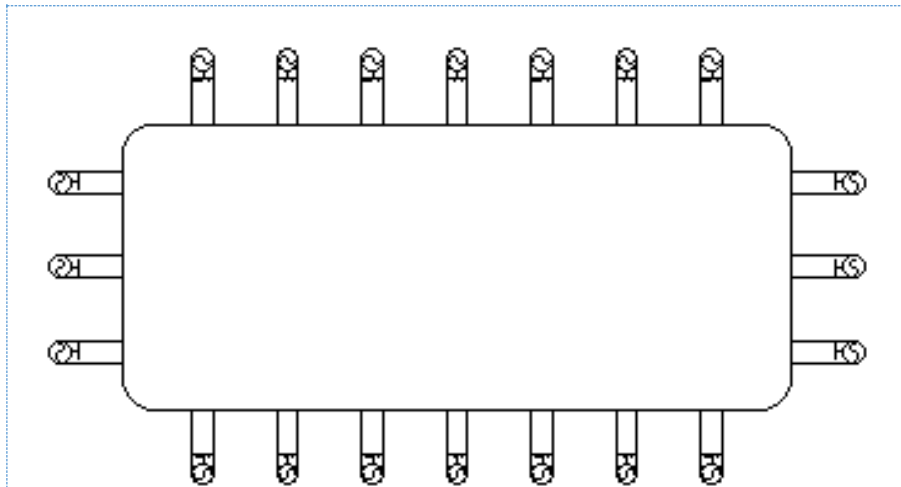

Figure 1. Representative Plan View of a Fan-supported Ground Pile

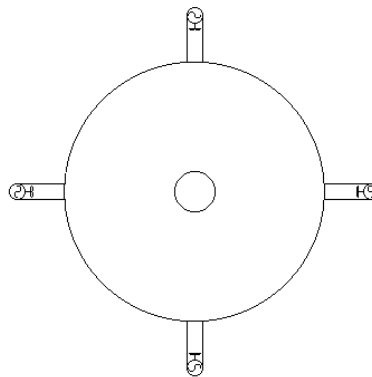

Figure 2. Representative Plan View of a Fan-supported Bin

Key benefits of the Extron Aeration Control include:

- Wireless communication and control
- Manage grain temperature and moisture content
- Ground pile tarp control
- Reduced shrinkage when fans are managed to support on-site conditions
- Energy savings when the fan speed is optimized to support on-site needs

In addition to providing fan speed control, the Extron Aeration Control uses sensors to collect data on the fan exhaust temperature, fan vacuum pressure, the carbon dioxide level (if equipped with the Extron CO2 Probe Option), and the current wind speed (if equipped with the Anemometer Option). This data is used for generating notifications and/or alarms on the Extron Remote Management website and used by the Extron Gateway to determine fan speed adjustments based on local conditions in real-time.

2.0 Scope and Audience

This document is intended for equipment specifiers and installers of Extron Aeration Control equipment.



3.0 Safety

Please read the entire instruction manual before installing or operating the device.

Table 1 provides nomenclature for information provided within this document. Failure to observe the warnings and cautions can lead to personal injury and/or equipment damage.

With installation and usage questions, contact Extron Company before proceeding.

Extron Company
(763) 544-4197
Fax: (763) 544-4419
sales@extroncompany.com

| Symbol | Description |
|---|---|
|  | <p>Warning:</p> <p>Indicates a hazardous situation that, if not avoided, could result in serious injury or death. Consult all cases where this symbol is used before installing or using the equipment.</p> |
|  | <p>Caution:</p> <p>Indicates a hazardous situation that, if not avoided, could result in equipment damage or minor to moderate injury. This guide provides explanatory information which clarifies and expands upon the importance of procedural steps where needed.</p> |
|  | <p>Notice:</p> <p>Indicates explanatory information which clarifies and expands upon the importance of the procedural step when needed. This symbol indicates information considered important but not hazard related.</p> |
| <p>Table 1: Warning, Caution, and Notice</p> | |

4.0 Features and Accessories

The Extron Aeration Control enclosure is a cabinet with front access through a keyed swing door. The enclosure supports equipment used for data collection and fan control with apertures and openings for field wiring connections to incoming power, local sensors, and to a single fan.

5.0 Product Description

| Part No | Fan HP | Voltage | Option |
|-------------|--------|-------------------|----------------------------|
| N170600740D | 7.5 | 480VAC, 60Hz, 3Ph | CO2, Humidity, Antenna Ext |

Part No. Configurator

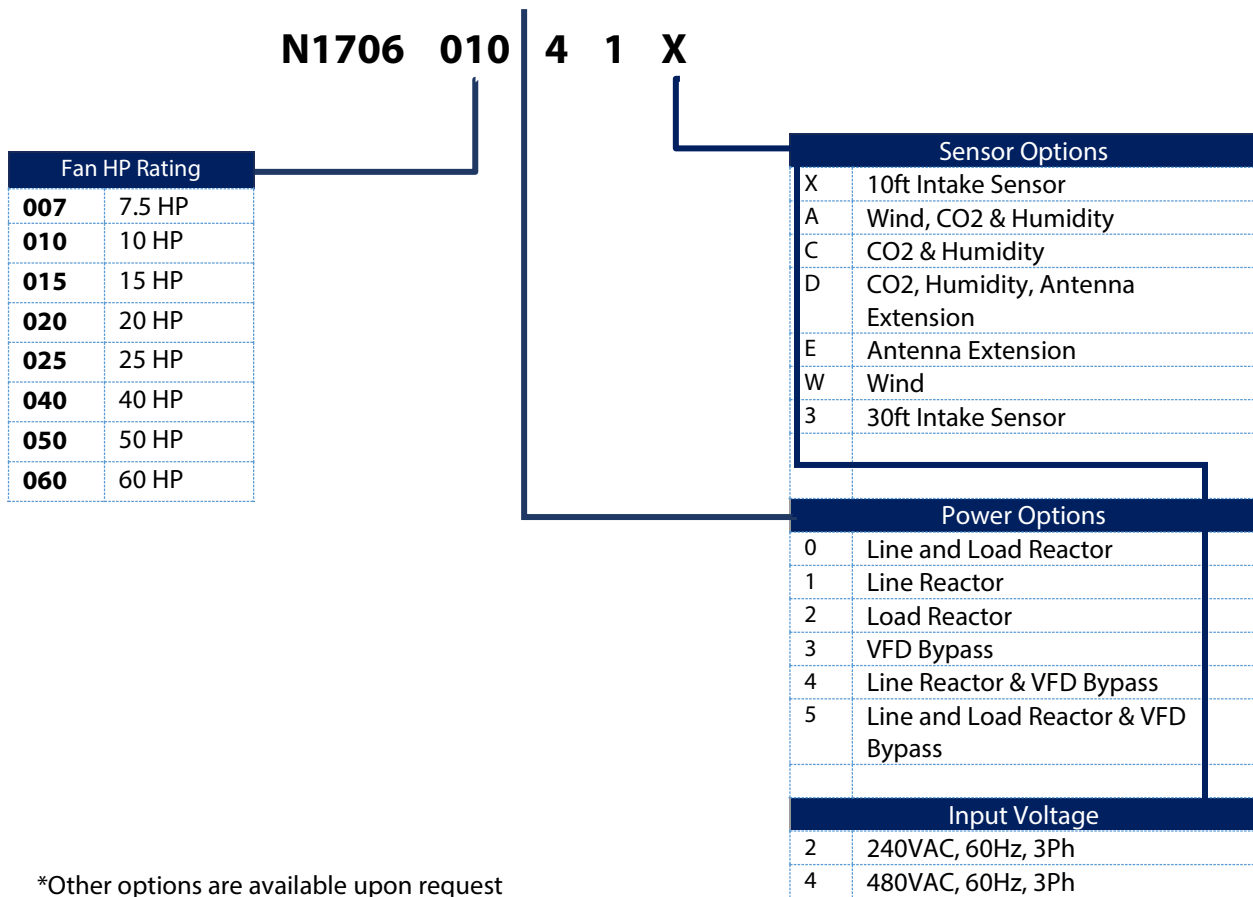

6.0 Mechanical Specifications

The table below identifies the enclosure size associated with the selected horsepower and voltage rating for each version of the Extron Aeration Control. The pages that follow in this section show the dimensions for the enclosure sizes listed in the table below.

| HP | Voltage | Enclosure Size |
|------------|---------|----------------|
| 5 | 480VAC | 1 (Obsolete) |
| 7.5 | 480VAC | 1 (Obsolete) |
| 10 | 480VAC | 1 (Obsolete) |
| 7.5 | 480VAC | 1.1 |
| 10 | 480VAC | 1.1 |
| 15 | 480VAC | 2 |
| 20 | 480VAC | 2 |
| 25 | 480VAC | 2 |
| 30 | 480VAC | 2 |
| 40 | 480VAC | 3 |
| 50 | 480VAC | 3 |
| 60 | 480VAC | 3 |

Table 2: Extron Aeration Control Enclosure Table

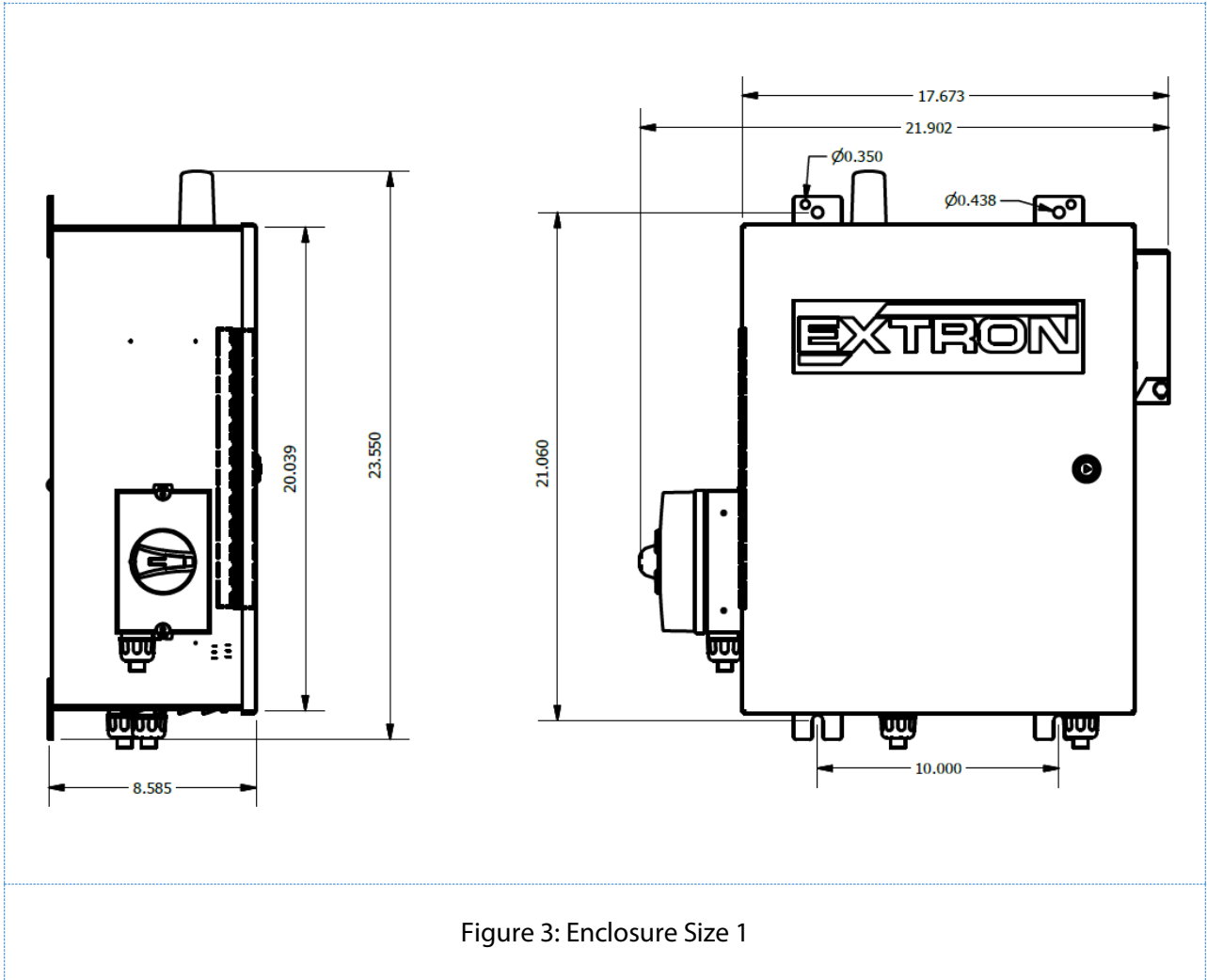
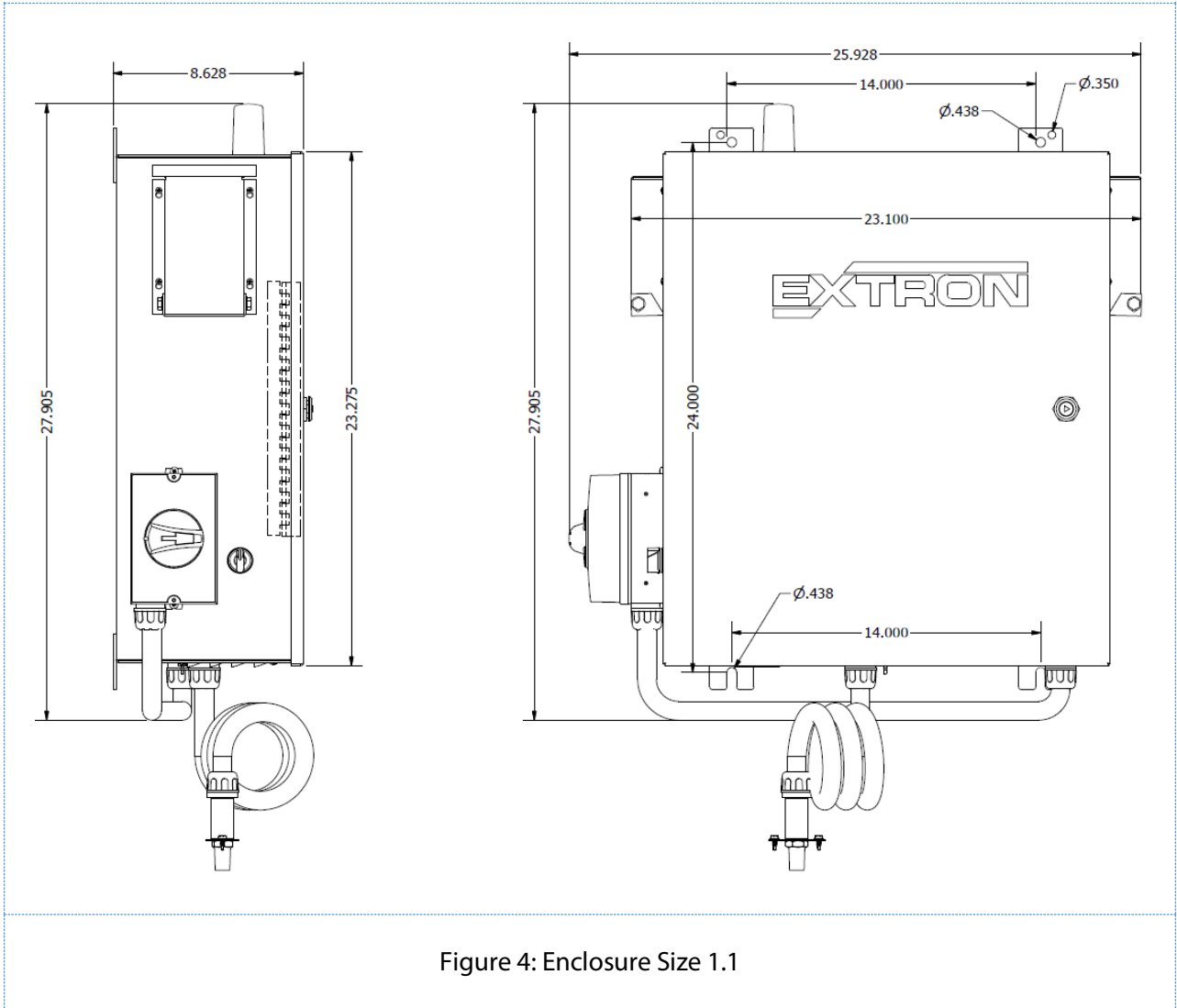
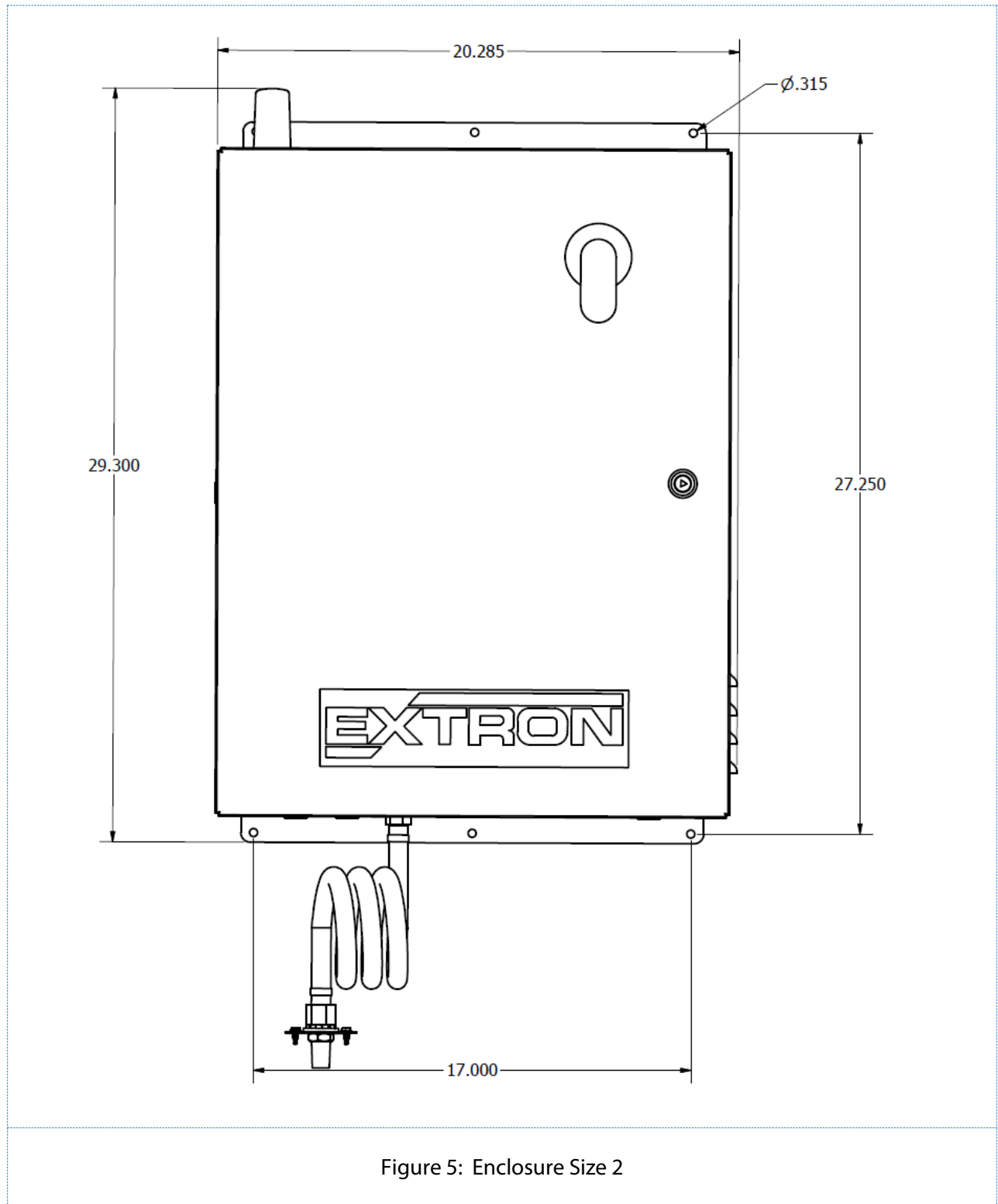

Figure 3: Enclosure Size 1





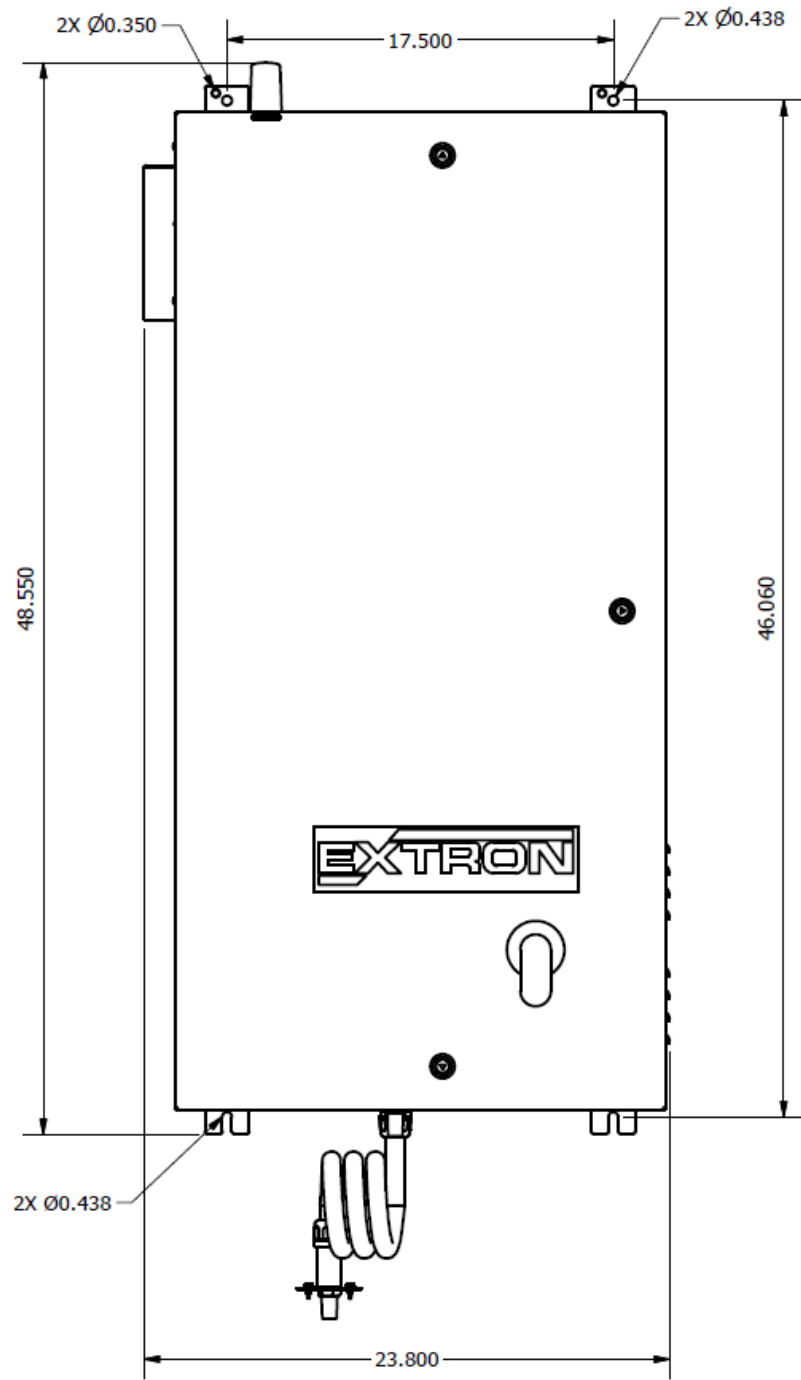

Figure 6: Enclosure Size 3

7.0 Electrical Specifications

| Parameter | | Min | Typical | Max | Units |
|------------------------------------|----------------------------|---|------------|-----------|----------|
| Input Voltage | N1706XXX2XX N1706XXX4XX | | 240 480 | | VAC |
| Operation Temperature ¹ | | -40 -40 | | 122 50 | °F °C |
| Vibration | | 1 mm (0.03 in) at 5...13.2 Hz (0.07...0.2 s) 0.075 mm (0.003 in) at 10...57 Hz (0.01 ...0.1 s) | | | |
| Communication | 900Mhz | <1000ft and in line of sight of the Extron Gateway or another Extron Aeration Controller | | | |

8.0 User Interface

Enclosure

The enclosure front door is secured by a triangle key.

Connectors and Connections

All wiring connections into the Extron Aeration Controller are made through the bottom surface of the enclosure.

Displays and Lighted Indicators

The VFD and Node Board provide power and fault indication LEDs; each is described below.

Communication

The Extron Aeration Controller communicates with the Extron Gateway through its top-mounted antenna. The communication mode is a 900 MHz mesh network and as a result, each Extron Aeration Controller must be within 1000ft and in line of sight of the Extron Gateway or another Extron Aeration Controller.

System Ventilation

The Extron Aeration Controller uses a built-in fan to circulate air internally. Do not allow adjacent equipment to impede with the fan exhaust at the top of the right side or the intake filter on the left side of the bottom surface.

¹ If the temperature inside the enclosure is above 104°F (40°C), the VFD output rating decreases by 2.5% for every additional 1.8°F (1°C).

9.0 Technical Specifications

Mechanical and Electrical Specifications; described above and within

10.0 Mechanical Installation

Mechanical Guidelines and System Requirements

| Select a Suitable Location | Extron Aeration Control Enclosure |
|--|--|
| Vertical, Level and Off the Ground | When the door is unlatched, the door should not 'fall' further open or closed on its own. The enclosure should be no less than 2ft off the ground. |
| Secure | Use proper bolts and mounting hardware to ensure the enclosure is fully affixed to its intended support structure |
| Unobstructed Enclosure Vents | Place the enclosure in a location where air drawn in or pushed out by the enclosure's fan is not impeded or restricted. |
| Dry - Prevent Water Ingress | Place the enclosure in a location where water (rain, runoff, etc.) does not impinge directly onto the enclosure. |
| Minimize Dirt and Dust Exposure and Ingress | Place the enclosure in a location that minimizes dust exposure. Verify the door fits properly and that large gaps between the door and the enclosure's cabinet do not exist. |
| Out of Direct Sunlight | Where possible, place the enclosure out of direct sunlight or in a location that minimizes the solar heat load |
| Out of Line of Fan Exhaust | Ensure that the airflow exhaust from the ground pile or bin fan does not impinge directly on the enclosure |
| Suitable Mechanical Operation of Electrical Components | Verify the proper mechanical operation of the components that provide the electrical supply |
| Conduit Fittings | Use proper fittings and ensure they are rated for the environmental conditions |
| Communication | The Extron Ground Pile System, and the Extron Aeration Controller, use a mesh network for radio communication between devices. Verify the Extron Aeration Control enclosure is within 1000ft and in line of sight of the Extron Gateway or another Extron Aeration Controller. |

| Ground Pile or Bin Fan | |
|------------------------|---|
| Off the Ground | A ground pile fan should not be resting directly on the ground. This condition can more quickly degrade the fan and wiring from the Extron Aeration Controller to the fan may be compromised. |
| Clean | Accumulated debris on the fan's blades or shaft can introduce vibration. A ground pile fan should not excessively shake or vibrate through any range of rotational speed. |
| VFD-Rated Fan | Verify the ground pile or bin fan is rated for control by a VFD |

11.0 Electrical Installation

Electrical Guidelines and System Requirements

- 1) Fan motors must be rated for operation with a VFD. This is commonly referred to as "Inverter Duty" or "Inverter Rated" and can usually be found on the motor's nameplate information. Non- "Inverter Duty" motors are not designed with adequate cooling when operating at less than full speed.
- 2) Use Shielded VFD Cable to connect the VFD to the fan motor.
 - a. Shielded VFD Cable helps to contain the electrical noise emitted by the VFD and will aid in protecting the motor and extending its longevity.
 - b. <https://www.belden.com/products/industrial/cable/vfd>
 - c. <https://www.belden.com/hubfs/resources/technical/installation-guides/unarmored-variable-frequency-drive-cable-termination-guide.pdf?hsLang=en>
- 3) Proper grounding of the VFD cable provides a low impedance path to dissipate the disruptive common mode currents generated by the VFD. Ensure that the braided shield of the VFD cable is properly grounded per the electrical drawing provided with the Extron Aeration Controller. Note that grounding the braided shield may vary by VFD manufacturer and this requirement will be clearly defined in the Extron Aeration Controller electrical drawing.
- 4) Ensure that the ground conductor within the Shielded VFD Cable is grounded at the motor and also grounded at the Extron Aeration Control enclosure.
- 5) Avoid installing plugs and receptacles in the Shielded VFD Cable as this will diminish the integrity of the cable and its braided shield.

- 6) Refrain from using wire nuts to make the Shielded VFD Cable connection to the motor leads. Instead, use crimp style ring lugs and bolt them together. Then wrap the bolted ring lugs with 3M 2520 Varnished Cambric tape, followed by 3M Scotch® Linerless Rubber Splicing Tape, then followed by 3M Super 33+ Vinyl tape.
- 7) It is important to protect the motor junction box from moisture. Ensure that the motor junction box is mounted such that water will not pool up inside from precipitation and cause a phase-to-phase short or ground fault situation.
- 8) If the fan motor is more than 100ft from the Extron Aeration Controller, installation of a load reactor is recommended to help protect the motor from the high voltages that can occur as a result of the reflected wave phenomenon.
 - a. The Extron Aeration Controllers shipped after 1/1/2019 include a Load Reactor.
- 9) Fan motors must be sized appropriately for the load. Fan motors that are overloaded (operating within their service factor) for extended periods of time will result in:
 - a. Decreased energy efficiency
 - b. Overheating and damage to the motor insulation
- 10) Fan motors must be rated for the conditions in which they will be operating. Moisture and high temperatures are two environmental conditions frequently encountered that can shorten the lifespan of a motor not rated for such conditions.



Warning:

Electrical Installation to be performed only by qualified personnel with adequate training and experience in installing industrial control panels and electric motors.

LOCK-OUT & TAG-OUT ELECTRICAL SERVICE BEFORE
INSTALLATION

Electrical Installation and Start-up

During the electrical installation and equipment start-up, follow the procedures step-by-step in the order shown below.

1) Verify Feeder Circuit Power

- Verify that the voltage of the feeder circuit matches the specifications on the wiring diagram for the Extron Aeration Control.
- Verify that the size of the feeder circuit lead wires matches the recommended gauge as specified in the wiring diagram for the Extron Aeration Control.

2) Lock-Out and Tag-Out the Feeder Circuit

- Disconnect power to the feeder circuit by implementing a lock-out and tag-out procedure. This must be completed before connecting the feeder circuit to the Extron Aeration Control. Visit osha.gov and search for "lock-out & tag-out" for further information or contact your company's safety officer.
- Use a digital volt meter that is set to measure AC voltage to confirm that power has been disconnected.

3) Connect the Feeder Circuit to the Extron Aeration Control

- Connect the feeder circuit lead wires and ground wire to the Extron Aeration Control as illustrated by the electrical wiring diagram that is sent with the Extron Aeration Control.
- If the feeder circuit power is a three-phase, solidly-grounded wye configuration, install the IT screws into the right-side of the VFD. Otherwise, leave the IT screws out. They can be found inside a plastic bag that is attached to the VFD.

4) Power Up the Extron Aeration Control

- After ensuring the safety of all personnel and equipment, remove the lock-out and tag-out on the feeder circuit that will power the Extron Aeration Control. Then energize the feeder circuit that will power the Extron Aeration Control.

5) Verify Voltage and Node Board Operation

- **Caution: the Extron Aeration Control will now be energized.** After dressing to the appropriate level of personal protective equipment (PPE) as directed by your company's safety officer, and in accordance to all applicable safety standards, open the door to the Extron Aeration Control.

- Using a digital volt meter that is set to read AC voltage, verify that all phase-to-phase voltages and all phase-to-ground voltages on the line side (top) of the VFD are in agreement with the electrical wiring diagram. If they are not, troubleshoot and resolve before proceeding. If a tripped circuit breaker or blown fuse is found, identify root cause of electrical problem before resetting the circuit breaker or replacing the blown fuse.
- After confirming that the voltage on the line side of the VFD is correct, examine the on/off behavior of the green LED on the Extron Node Board.
 - o If the green LED toggles slowly and steadily between on and off, then the Extron Node Board operation is normal. Proceed with the installation and start-up.
 - o If it rapidly flashes multiple times between pauses, then refer to the troubleshooting section of this manual for more information before proceeding.

6) Lock-Out and Tag-Out the Feeder Circuit Again

- Disconnect power again to the feeder circuit by implementing a lock-out and tag-out procedure. This must be completed before wiring the motor to the Extron Aeration Control.
- Use a digital volt meter that is set to measure AC voltage to confirm that power has been disconnected.

7) Motor Insulation Test

- Use a megohmmeter insulation tester (also known as a “megger”) to verify the integrity of the motor insulation. Follow the instructions provided with your megger in order to properly and safely perform the insulation test. If the motor fails the insulation test, replace it before proceeding with the rest of the Extron Aeration Control installation and start-up.

8) Connecting the Cable from the VFD to the Fan Motor

- Connect one end of the Shielded VFD Cable to the Extron Aeration Control. Reference the wiring diagram when making the connection as some Extron Aeration Controllers may have a load reactor installed. The ground conductor and braided shield within the Shielded VFD Cable must be properly connected inside the Extron Aeration Control enclosure.
- Connect the other end of the Shielded VFD Cable to the motor leads inside the motor junction box. All connections in the motor junction box should be made using crimp style ring lugs that are bolted together. Then wrap the bolted ring lugs with 3M 2520 Varnished Cambric tape, followed by 3M Scotch® Linerless Rubber Splicing Tape, then followed by 3M Super 33+ Vinyl tape. The ground conductor and braided shield within the Shielded VFD Cable must be properly connected inside the motor junction box.

9) Power Up the Extron Aeration Control Again

- Close the door to the Extron Aeration Control.
- After ensuring the safety of all personnel and equipment, remove the lock-out and tag-out on the feeder circuit that will power the Extron Aeration Control. Then energize the feeder circuit that will power the Extron Aeration Control.

10) Verify Fan Operation

- The fan should turn on and ramp up to a speed which is determined by the Extron Gateway. If the Extron Gateway is not powered on or not within range of the Extron Aeration Control, the fan will run at 100% unless the Extron Aeration Control is in a mode other than Auto or Force Max.
- Verify that the fan is turning in the correct direction. If the fan is turning backwards, lock-out and tag-out the power source before switching any two motor leads connected to the load side (bottom) of the VFD.
- For Extron Aeration Controllers that have the bypass option, it is also necessary to confirm the fan direction while operating in bypass. Refer to Section 3.3 for information on how to force the Extron Aeration Control into bypass. If the fan turns backwards while operating in bypass, lock-out and tag-out the power source before switching any two feeder circuit leads that connect to the main disconnect switch.
- As a final step, confirm that the fan does not vibrate throughout the entire frequency range (20Hz to 60Hz). An unbalanced fan can lead to vibration that can shorten the lifespan of the motor.

12.0 Operation and Use

12.1 Commissioning

See Mechanical Installation and Electrical Installation. Once complete and power is applied, the Extron Aeration Controller will begin to communicate with the local Extron Gateway.

12.2 Use

Ground Pile Operation

There are several different modes of operation available for the ground piles. Mode selection can be made from the Extron Remote Management website. These modes can be further defined as follows:

- **Wind-Only Mode:** This mode of operation is designed to simply ramp the speed of the ground pile fans relative to the wind speed in order to keep the tarp down on the ground pile. The speed of the ground pile fans will be adjusted based on the last reported wind speed.

- **Cool Mode:** This mode of operation is designed to run the ground pile fans at full speed when the environmental conditions are favorable in cooling the ground pile by aeration. The ground pile fans will run at full speed if all of the following conditions are met; otherwise the ground pile fans will operate in Wind-Only Mode to provide only enough vacuum on the tarp in order to keep it in place.
 - o The ambient humidity must be less than or equal to the ground pile humidity setpoint.
 - o The ambient temperature must be less than the ground pile grain temperature setpoint.
 - o The ground pile temperature must be higher than the ground pile grain temperature setpoint.

- **Warm Mode:** This mode of operation is designed to run the ground pile fans at full speed when the environmental conditions are favorable in warming the ground pile by aeration. The ground pile fans will run at full speed if all of the following conditions are met; otherwise the ground pile fans will operate in Wind-Only Mode to provide only enough vacuum on the tarp in order to keep it in place.
 - o The ambient humidity must be less than or equal to the ground pile humidity setpoint.
 - o The ambient temperature must be greater than the ground pile grain temperature setpoint.
 - o The ground pile temperature must be lower than the ground pile grain temperature setpoint.

Bin Operation

There are several different modes of operation available for the bins. Mode selection can be made from the Extron Remote Management website. The various bin modes can be further defined as follows:

- **Off:** All fans in the current bin that are set to Auto mode will be turned off.
- **On:** All fans in the current bin that are set to Auto mode will be turned on.
- **Cool:** In Cool mode, the fans that are set to Auto mode will be turned on if the ambient temperature is less than the grain temperature setpoint and the ambient humidity is less than the humidity setpoint and the maximum cable temperature is above the grain temperature setpoint.
- **Warm:** In Warm mode, the fans that are set to Auto mode will be turned on if the ambient temperature is greater than the grain temperature setpoint and the ambient humidity is less than the humidity setpoint and the maximum cable temperature is below the grain temperature setpoint.

Extron Aeration Control Operation

Within a ground pile or bin, each Extron Aeration Control can be assigned a mode of operation independent from one another. The mode of operation can be changed from the Extron Remote Management website. The available modes are listed below:

- **Auto:** The fan speed will be controlled by the ground pile or bin operational mode. Speed can vary between 100% and the value set by the minimum fan speed setpoint on the Extron Remote Management website.
- **Force Max:** The fan will run at 100% speed.
- **Force Min:** The fan speed will run at the minimum allowable speed as determined by the minimum fan speed setpoint. This setpoint is accessible on the Extron Remote Management website and applies to all Extron Aeration Controllers within a given ground pile.
- **Disabled:** The fan will be disabled from operation.
- **Fixed %:** The fan will run at the fixed fan speed setpoint. This setpoint is accessible on the Extron Remote Management website and applies to all fans within a given ground pile or bin which are assigned to this mode of operation.

The Extron Aeration Control can also be purchased with a bypass option. The bypass option includes a two-position selector switch which provides a means to manually force the Extron Aeration Control into a bypass mode where the VFD is no longer controlling the fan speed. Once in bypass, the fan will be controlled by an across-the-line motor starter instead of the VFD. Procedures for switching into or out of bypass are as follows:

- 1) Locate the main disconnect switch and turn off all power to the Extron Aeration Control.
- 2) Turn the two-position selector switch to the desired state (either Auto or Bypass).
- 3) Use the main disconnect switch to turn the Extron Aeration Control power back on again.

**Caution:**

Never turn the bypass switch while the Extron Aeration Control is energized. Doing so may result in equipment damage or failure.

13.0 FAQ and Troubleshooting

| Problem | Possible Causes |
|---|--|
| <p>Suspected VFD Fault</p> | <ul style="list-style-type: none"> - Verify all conditions including fan state, system wiring and the state of incoming power - The VFD has two ERR LEDs along its right hand edge: one in the upper right corner and one centered. Verify neither ERR LED is on. - Obtain the drive fault code ('Drv Fault Code') reported by Extron Remote Management and contact Extron support for additional information and instructions. <div style="text-align: center; border: 1px solid gray; padding: 10px; margin: 10px 0;"> <p>Select Options ▼</p> <p>Status: OK Mode: Fixed % Fan Speed: 75% Fan RPM: 2620 Power Usage: 40% Power: 2.8kW Vacuum: 27.6"W.C. Exhaust Temp: Disabled Current: 7.20A Voltage: 461VAC Cost Saving: \$3149 Drv Fault Code: 0</p> <div style="border: 1px solid black; padding: 5px; margin-top: 5px;"> <p>Last Comm Fan 06 11/4/2019 SN: 17005 1:19 PM</p> </div> </div> <ul style="list-style-type: none"> - Remove the fan load from the VFD. Cycle power on the VFD. If the VFD does not come back up, it needs replacement. |
| <p>Fan does not turn on (always at 0 RPM)</p> | <ul style="list-style-type: none"> - Tripped circuit breaker or blown fuse in Extron Aeration Control - VFD fault in Extron Aeration Control - Extron Aeration Control disabled in Extron Gateway - Extron Aeration Control not programmed into Extron Gateway - Extron Gateway not powered - Extron Aeration Control not within range of the Extron Gateway |

| | |
|---|---|
| <p>Fan Motor Failures</p> | <ul style="list-style-type: none"> - Motor not rated as “Inverter Duty” or not rated for the environmental conditions to which it has been subjected. - Motor junction box not watertight. Water within the motor junction box can result in a phase-to-phase short or a ground-fault condition. - Verify a low impedance path exists between the motor and earth ground by means of a properly-terminated ground wire from the VFD to the motor or with a properly-sized and terminated grounding strap from the motor’s frame to earth ground. - Ensure shielded VFD cable has been installed between the VFD and the motor. Failure to use shielded VFD cable can lead to damaging levels of high common mode voltage. Ensure the cable and its shield has been properly terminated as specified in the Electrical Installation section of this guide. - Where premature bearing failures or bearing fluting is seen: <ol style="list-style-type: none"> 1. Reduce circulating currents within the motor by installing a common mode choke (inductive absorber) around the power conductors on the load side of the drive (i.e. around the cables from the VFD / Load Reactor to the motor). 2. Reduce electrical discharge currents caused by capacitively coupled common mode voltage on the motor’s shaft by: <ol style="list-style-type: none"> a. Isolating or insulating the non-drive end of the motor, b. After verifying a conductive motor shaft, install a shaft grounding ring around the motor’s shaft. A shaft grounding ring conducts potentially harmful shaft voltages away from the motor’s bearings to ground. - Extron support can provide additional guidance on these solution |
| <p>Does not read pressure</p> | <ul style="list-style-type: none"> - Intake hose is not connected to the fan ductwork. |
| <p>Does not read wind speed (Wind Option)</p> | <ul style="list-style-type: none"> - Anemometer cable not connected. - Anemometer wired incorrectly. |
| <p>Does not read the correct CO2 (CO2 Option)</p> | <ul style="list-style-type: none"> - Exhaust hose not connected to the fan exhaust. |

Variable Frequency Drive / Inverter Fault Codes

- The Inverter provides fault codes that indicate its current state
- If the inverter is reporting a fault, it can be seen on the ERM. If not displayed, click on the Select Options drop-down and enable the checkbox next to 'Drv Fault Code'

Select Options 

Status: OK
Mode: Fixed %
Fan Speed: 75%
Fan RPM: 2620
Power Usage: 40%
Power: 2.8kW
Vacuum: 27.6"W.C.
Exhaust Temp: Disabled
Current: 7.20A
Voltage: 461VAC
Cost Saving: \$3149
Drv Fault Code: 0



| | |
|------------------|---------------|
| Last Comm | Fan 06 |
| 11/4/2019 | SN: 17005 |
| 1:19 PM | |

- For the full list of Lenze i550 Fault Codes, see Appendix Error Codes

Problem: Node Board Not Communicating.

- The green LED located on the Extron Node Board can be a valuable tool when troubleshooting problems that have occurred. Use the table below to gain an understanding of what the LED flashes represent. Note that it may take over five minutes for the LED status to reflect a loss in communication.

| Green LED | Status |
|-----------------------------|---|
| Off | No power on the Extron Node Board |
| Steady On/Off Toggle | Normal operation |
| 2 Flashes | No communication with VFD |
| 3 Flashes | No communication with Extron Gateway |
| 4 Flashes | No communication with VFD or Extron Gateway |

When the green LED is off, there is no 24VDC power applied to the Extron Node Board. Perform the following checks:

- Check that 24VDC power is being supplied by the power supply unit inside the Extron Aeration Control enclosure.
- Check that the power supply unit is providing 24VDC power to pins 2 and 9 on the blue connector (J8).
- Check that the blue connector on the Node Board is seated properly.

When the green LED flashes rapidly two times between pauses, the Extron Node Board has lost communication with the VFD. Perform the following checks:

- Check that the VFD has the correct AC voltage across all three phases on the input terminals L1, L2, and L3. Refer to the wiring diagram that is sent with the Extron Aeration Control unit for more information.
- Check that the cable that connects between the Node Board and the VFD. Ensure that it is properly seated at both ends. Inspect the cable for any damage. Refer to the wiring diagram that is sent with the Extron Aeration Control unit for more information.

When the green LED flashes rapidly three times between pauses, the Extron Node Board has lost communication with the Extron Gateway. Perform the following checks:

- Check that the Extron Gateway is powered on.
- Check that the Extron Aeration Control unit is programmed into the Extron Gateway.
- Check that the Extron Aeration Control unit is within range of the Extron Gateway.

When the green LED flashes rapidly four times between pauses, the Extron Node Board has lost communication to the Extron Gateway and the VFD. Perform the following checks:

- Follow all checks for when the LED flashes rapidly two times between pauses.
- Follow all checks for when the LED flashes rapidly three times between pauses.

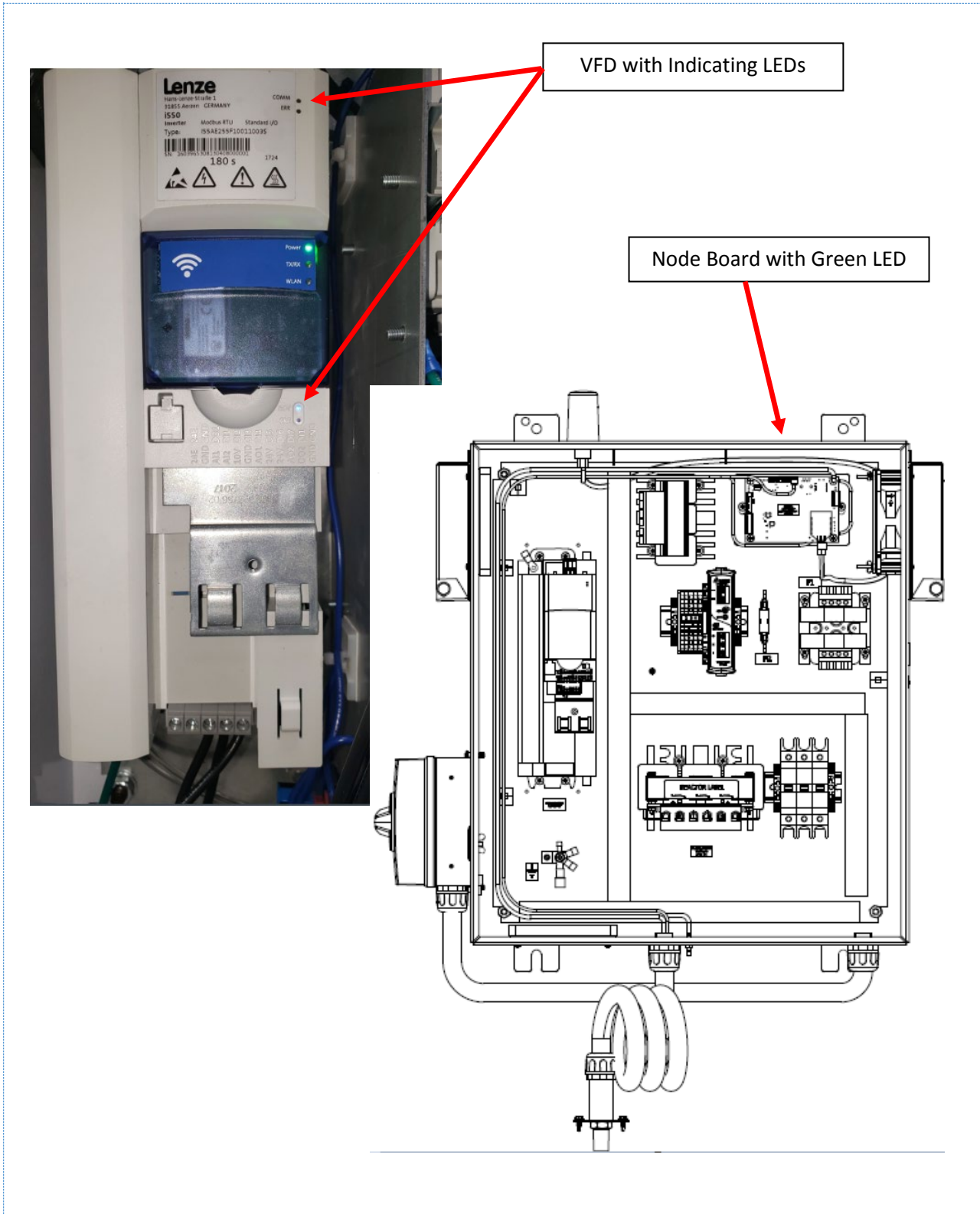

14.0 Preventative Maintenance

| | |
|---|--|
|  | <p>Warning:</p> <p>Preventive maintenance to be performed by qualified personnel only.</p> <p>LOCK-OUT & TAG-OUT ELECTRICAL SERVICE BEFORE PERFORMING MAINTENANCE</p> |
|---|--|

Regular preventive maintenance can extend the service life of the equipment and aid in preventing untimely and costly equipment failures. It is highly recommended to adopt the following procedures into your regular maintenance program.

- 1) Clean the debris out of the Extron Aeration Control enclosures on a monthly basis when the ground pile fan or bin fan is actively running. It is especially important to ensure that the Extron Aeration Control enclosures stay clean and dry on the interior as dirt and moisture can significantly reduce the lifespan of the VFD. Vacuuming is the preferred method of cleaning as it avoids blowing contaminants into the components. If vacuuming does not remove all dirt and debris, wipe down the inside of the enclosure and components with a cloth. Inspect the ventilation filters to see if they need to be replaced. Inspect the rain-hoods to be certain that they are also clear of debris. Follow a lock-out and tag-out procedure to ensure power is off before cleaning.
- 2) Periodically inspect the motor junction boxes for standing water. If standing water has been confirmed, take action to remedy the situation. Consider relocating the junction box if necessary.
- 3) Periodically clean the fan blades to prevent unwanted vibration due to an unbalanced fan. An unbalanced fan can lead to substantial stress on the motor and a higher current draw. If left unchecked, this can be destructive to the motor. Check for vibration throughout the entire operating range.
- 4) Follow the motor manufacturer's preventive maintenance program regarding motor grease and lubrication. Consider the following recommendations:
 - a. Use the correct type of lubricant
 - b. Avoid accidental introduction of contaminants into the lubricant (i.e. clean grease fittings prior to filling)
 - c. Check for loss of lubricant
 - d. Don't over grease
- 5) Always protect the Extron Aeration Controllers from fumigation. The gases used during fumigation can be corrosive to many of the components within the Extron Aeration Control.

The green LED located on the Extron Node Board can be a valuable tool when troubleshooting problems that have occurred. Use the table below to gain an understanding of what the LED flashes represent. Note that it may take over five minutes for the LED status to reflect a loss in communication.

| Green LED | Status |
|-----------------------------|---|
| Off | No power on the Extron Node Board |
| Steady On/Off Toggle | Normal operation |
| 2 Flashes | No communication with VFD |
| 3 Flashes | No communication with Extron Gateway |
| 4 Flashes | No communication with VFD or Extron Gateway |

When the green LED is off, there is no 24VDC power applied to the Extron Node Board. Perform the following checks:

- Check that 24VDC power is being supplied by the power supply unit inside the Extron Aeration Control enclosure.
- Check that the power supply unit is providing 24VDC power to pins 2 and 9 on the blue connector (J8).
- Check that the blue connector on the Node Board is seated properly.

When the green LED flashes rapidly two times between pauses, the Extron Node Board has lost communication with the VFD. Perform the following checks:

- Check that the VFD has the correct AC voltage across all three phases on the input terminals L1, L2, and L3. Refer to the wiring diagram that is sent with the Extron Aeration Control unit for more information.
- Check that the cable that connects between the Node Board and the VFD. Ensure that it is properly seated at both ends. Inspect the cable for any damage. Refer to the wiring diagram that is sent with the Extron Aeration Control unit for more information.

When the green LED flashes rapidly three times between pauses, the Extron Node Board has lost communication with the Extron Gateway. Perform the following checks:

- Check that the Extron Gateway is powered on.
- Check that the Extron Aeration Control unit is programmed into the Extron Gateway.
- Check that the Extron Aeration Control unit is within range of the Extron Gateway.

When the green LED flashes rapidly four times between pauses, the Extron Node Board has lost communication to the Extron Gateway and the VFD. Perform the following checks:

- Follow all checks for when the LED flashes rapidly two times between pauses.
- Follow all checks for when the LED flashes rapidly three times between pauses.

15.0 Spares, Repair and Replacement

The Extron Aeration Control supports specific devices by voltage and HP performance.

Line Reactor

| HP | Voltage | LINE REACTOR | Extron PN |
|------------|---------|----------------------------------|------------|
| 7.5 | 480VAC | LINE REACTOR 480VAC 3PH 7.5HP 3% | 2100144700 |
| 10 | 480VAC | LINE REACTOR 480VAC 3PH 10HP 3% | 2100144800 |

Load Reactor

| HP | Voltage | LOAD REACTOR | Extron PN |
|------------|---------|-------------------------------------|------------|
| 7.5 | 480VAC | LOAD REACTOR, 480VAC 3PHASE 10HP 3% | 2100162100 |
| 10 | 480VAC | LOAD REACTOR, 480VAC 3PHASE 10HP 3% | 2100162100 |

VFD

| HP | Voltage | VFD | Extron PN |
|------------|---------|---|------------|
| 7.5 | 480VAC | STANDARD INVERTER DRIVE, ACTECH-LENZE I550 INVERTER MODBUS RTU STD I/O 7.5 HP 3PH 480V (IP20) | 2100154300 |
| 10 | 480VAC | STANDARD INVERTER DRIVE, ACTECH-LENZE I550 INVERTER MODBUS RTU STD I/O 10 HP 3PH 480V (IP20) | 2100164200 |

Common

| Item | Description | Extron PN |
|----------------------|---|------------|
| ANTENNA | ANTENNA 900MHz | 3400006925 |
| DISCONNECT SW | ENCLOSED DISCONNECT SWITCH, 3-POLE, 30A, UL 508 | 2000795900 |
| DOOR KEY | KEY 7MM TRIANGLE QTR TURN | 2610000100 |
| FAN | FAN AXIAL 120X38MM 24VDC 150CFM | 1400068400 |

16.0 Ordering Information

Contact Extron for pricing and availability

17.0 End of Life



This product may contain electrical wiring, components, devices, and enclosures that should not be placed into the residential waste stream.

At end of life and with prior approval by Extron Return Materials Authorization (RMA), Extron Company may accept any of our products into our manufacturing facility (Gaylord, MN USA) for disassembly and proper disposal. Extron Company may opt to perform this disassembly and disposal for a fee, and the end-user is responsible for charges related to collection and shipping hardware to Extron Company.

Product contains:

- Sheet metal enclosure / Sheet metal components
- Electrical Interconnection Wiring
- Fully-assembled electrical device
 - Circuit breaker
 - Fuse(s)
 - Variable Frequency Drive / Inverter
 - Power Supply
 - Line and/or Load Reactor
 - Internal Ventilation Fan
 - Switches, Button, Toggles
- Hardware, including fasteners and connectors

Contact Extron Company for additional End of Life support instructions.

18.0 Regulatory Declaration and Agency Information

Contains FCC ID: MCQ-XB900HP

The enclosed device complies with Part 15 of the FCC Rules. Operation is subject to the following two conditions: *(i.)* this device may not cause harmful interference and *(ii.)* this device must accept any interference received, including interference that may cause undesired operation.

19.0 Warranty

Extron Company warrants to the original purchaser all equipment and products manufactured by it and bearing its name to be free of defects in material and workmanship under normal use and service for a period of twelve (12) months from date of purchase from Extron. This warranty is applicable only if the Extron product and/or equipment is installed, operated and maintained in accordance with factory recommendations and procedures.

In the event the Extron product and/or equipment is found to be defective within the above-stated twelve (12) month period, Extron will repair or replace defective parts if the product or equipment is shipped prepaid to Extron's factory and if such product and/or equipment is found by Extron's inspection to be truly defective in workmanship or material. Extron will return-ship such repaired product and/or equipment prepaid within the continental United States. If Extron's inspection does not disclose any defect in workmanship or material, repairs will be made at a reasonable charge.

THE WARRANTIES SET FORTH HEREIN ARE IN LIEU OF ANY AND ALL OTHER WARRANTIES EXPRESSED OR IMPLIED, INCLUDING THE WARRANTIES OF MERCHANTABILITY AND FITNESS FOR PURPOSE AND THE BUYER ACKNOWLEDGES THAT NO OTHER REPRESENTATIONS WERE MADE TO HIM OR RELIED UPON BY HIM WITH RESPECT TO THE QUALITY AND FUNCTION OF THE GOODS HEREIN SOLD.

LIMITATIONS OF LIABILITY

IN NO EVENT, WHETHER AS A RESULT OF BREACH OF CONTRACT, WARRANTY OR TORT (INCLUDING NEGLIGENCE), SHALL EXTRON OR ITS SUPPLIERS BE LIABLE FOR ANY CONSEQUENTIAL OR INCIDENTAL DAMAGES, INCLUDING FOR PURPOSES OF ILLUSTRATION, BUT NOT FOR LIMITATION, LOSS OF PROFITS OR REVENUES, LOSS OF USE OF EQUIPMENT FURNISHED OR SERVICED BY EXTRON, DAMAGE TO, OR LOSS OF USE OF, ANY ASSOCIATED EQUIPMENT, COST OF CAPITAL, COST OF SUBSTITUTE OR REPLACEMENT PRODUCTS, FACILITIES, SERVICE OR POWER, DOWN TIME COSTS, OR CLAIMS OF THE CUSTOMER'S CUSTOMER FOR SUCH DAMAGES. IF THE CUSTOMER TRANSFERS TITLE TO OR LEASES THE PRODUCTS SOLD OR SERVICED HEREUNDER TO ANY THIRD PARTY, THE CUSTOMER SHALL OBTAIN FROM SUCH THIRD PARTY A PROVISION AFFORDING TO THE COMPANY AND ITS SUPPLIERS THE PROTECTION OF THE PRECEDING SENTENCE, AND THE CUSTOMER WILL DEFEND AND HOLD EXTRON HARMLESS FROM ANY CLAIMS OF SUCH THIRD PARTIES.

EXTRON'S LIABILITY ON ANY CLAIM OF ANY KIND (INCLUDING NEGLIGENCE) FOR ANY LOSS OR DAMAGE ARISING OUT OF OR RESULTING FROM THIS AGREEMENT, OR FROM THE PERFORMANCE OR BREACH THEREOF, OR FROM THE PRODUCTS OR SERVICES FURNISHED HEREUNDER, SHALL IN NO CASE EXCEED THE PRICE OF THE SPECIFIC PRODUCT OR SERVICE WHICH GIVES RISE TO THE CLAIM ALL SUCH LIABILITY SHALL TERMINATE UPON THE EXPIRATION OF THE WARRANTY PERIOD OF TWELVE (12) MONTHS, AS HEREINABOVE STATED.

The furnishing of advice or other assistance without separate compensation therefore will not subject the company to any liability, either in contract, warranty, tort (including negligence), or otherwise.

Each of the foregoing paragraphs in this article will apply to the full extent permitted by law. The invalidity, in whole or part, of any paragraph will not affect the remainder of such paragraph or any other paragraph.

20.0 Normative Document References

For background and theory of operation information a VFD, click here:

https://en.wikipedia.org/wiki/Variable-frequency_drive

VFD Cable, Belden reference datasheet

<https://www.belden.com/products/industrial/cable/vfd>

<https://www.belden.com/hubfs/resources/technical/installation-guides/unarmored-variable-frequency-drive-cable-termination-guide.pdf?hsLang=en>

OSHA: Control of Hazardous Energy (Lock-out/Tag-out)

<https://www.osha.gov/SLTC/controlhazardousenergy/>

21.0 Copyright

©2019 Extron Company, Minneapolis MN USA

All rights reserved

Patent pending, where applicable

22.0 Support Contact

Extron Company

15400 Medina Rd.

Plymouth, MN 55447

(763) 544-4197

techsupport@extroncompany.com

sales@extrongrain.com